

B-TRACK 16



MECALAC BASED

- ▶ Hydrostatische vierwielaandrijving en vierwielsturing
- ▶ PLC / Radio gestuurd
- ▶ Spoorasdruk elektronisch gestuurd
- ▶ Trekcapaciteit 1.600 ton
- ▶ Tara van 16 ton

 **B-TRACK**



B-TRACK 16

Motor	Merk	Deutz
	Vermogen	136 PK / 100 kW
	Koppel	520 Nm bij 1.500 t/min
	Injectie	Common Rail
Max. snelheid	Ongeladen	20 km/u
Compressor	Schroef	2.000 liters/min 10 bar
PLC Besturing	CAN-bus	IFM
Transmissie	Hydrostatisch	Bosch-Rexroth
Afmetingen		H: 3.100 mm L: 7.140 mm B: 2.400 mm

Gewicht (ca.)	16.000 kg
Tractie op de haak (gegarandeerd)	80 kN
Trekbare last (gegarandeerd)	1.600 T



Draaistraal	5 m
Besturing	Voorwiel-, vierwiel- en krabbesturing
Standaard haak	UIC haak / BSI (optie)
Opstap treden	Vooraan (optie)
Diagnose	Permanente mobiele data-overdracht
Onderhoud	Vereenvoudigd onderhoudsplan alle 500 werkuren
Economie	Laag diesel verbruik ± 8 l/u en minder onderhoud Snelle return on investment
Rendement	Compressor met groot debiet, bespaart tijd bij het beluchten van de wagons. Automatische controle van de spoorasdruk, waardoor constante tractie.
Opties	<ul style="list-style-type: none"> • Radiobesturing met display • ATEX kit • Verschillende types koppelsystemen

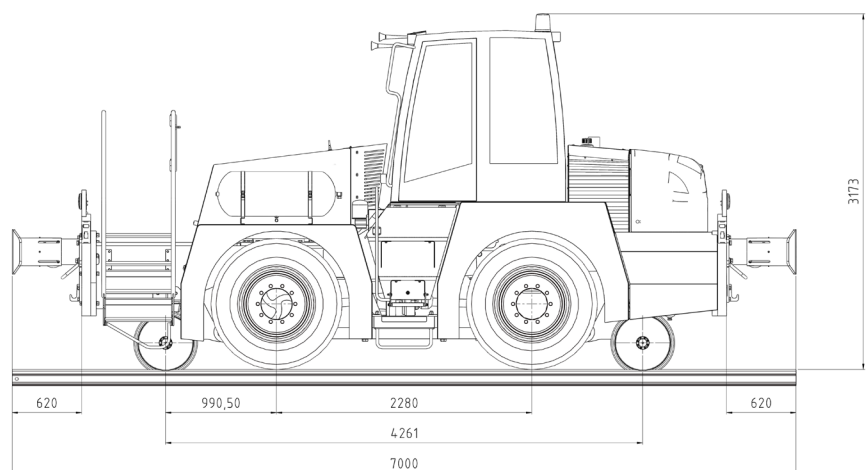
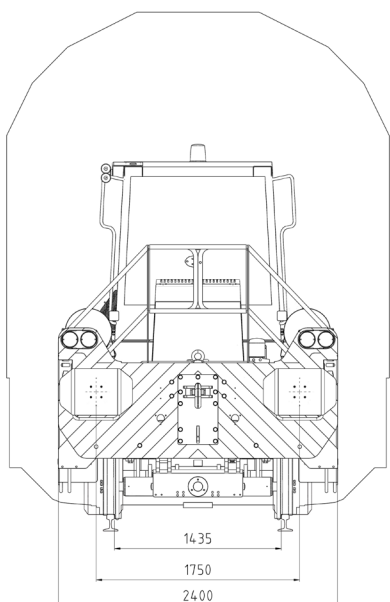



The RailRoad Factory Ltd

Unit E3 Southlink Park
Frankfield
Cork
Rep. Of Ireland
Email: trrf@trrf.ie
Tel: + 353 (0)21 432 01 08
www.trrf.ie



Société ETIC S.a.r.l.

Quartier Camp Jouven
RD 19
13450 Grans
France
Email: info@etic13.eu
Tél: +33 (0)4 90 50 55 00
Fax: +33 (0)4 90 42 70 39
www.etic13.eu



RENTALOC BVBA

Industriestraat 6
2500 Lier
België
Email: info@rentaloc.be
Tel: +32 (0)3 491 09 28
Fax: +32 (0)3 636 37 73
www.rentaloc.be